

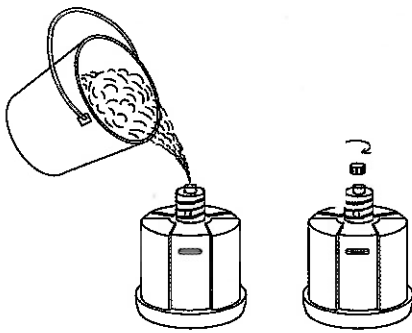

Freestanding Bag Assembly Instructions

STEP-1

Fill the base with water or sand using a standard garden hose is best. If not, use a funnel to help keep water or sand from splashing outside the fill hole.



STEP-2

Replace and tighten the fill cap.

STEP-3

Pull the plastic pole out from punching bag until see two holes

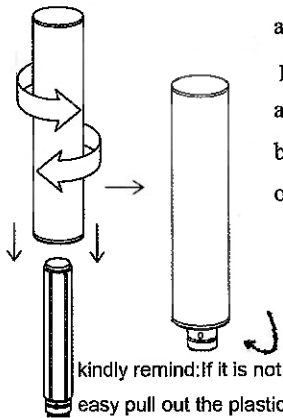

kindly remind: If it is not easy pull out the plastic pole from punching bag, we can use some lubricant, like dish washing liquid to reduce friction in between rubber and plastic.

STEP-4

Attach the flexible rubber base attachment to the base, matching up the two holes on the attachment and base. Next attach the top center pole to the rubber base attachment, also matching the two holes on the bottom of the center pole and the top of the rubber base attachment.

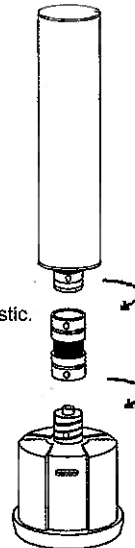

STEP-5

Secure the four holes – two on the top and two on the bottom – of the flexible rubber base attachment with the four rubber plugs on opposite sides to keep it in place.

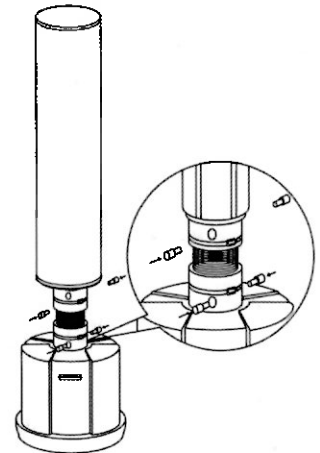

STEP-6

Cover the four holes with rubber plugs inserted with the two steel clamps, and secure.

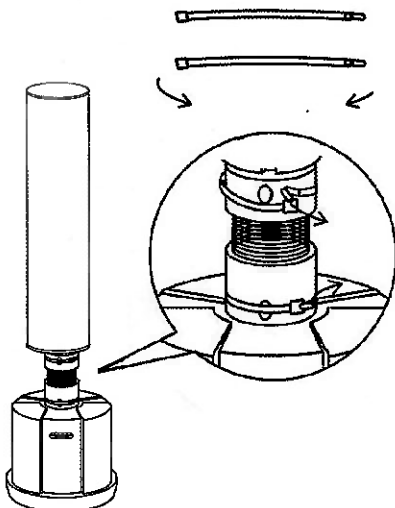

STEP-7

pull the bag down and twist it until it sits just above the base

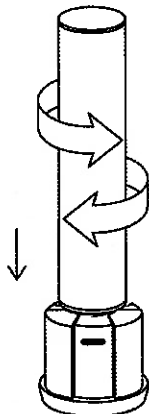

STEP-8

The bag is ready for use. Please note that the bag can be tilted so the base is at about a 45-degree angle, and easily rolled to and from the workout area, making it more portable, and keeping it out of the way when not in use

