

POWER STREAM

RACKS, BENCHES & ACCESSORIES

Half Racks | Full Racks | Wall Mounted Racks
Benches | Accessories



**The configurations
are endless.**

Our racks are modular and customizable. Made with premium 3" x 3", 11-gauge steel and power-welded, they're designed and engineered to withstand the heaviest weights and the toughest workouts. Our full line of racks is designed to meet your needs and the needs of your customers. You can start with the basics or move up to our most advanced system. All our racks offer a wide array of attachments, customizable storage, and innovative accessories. The set-ups and configurations are endless, limited only by your creativity.



FORCE RACK ZR



The ZR combines the strength and durability you expect from top-tier racks. Constructed from the same high-quality 3"x 3" 11-gauge steel as our HR1 and HR2 models, the ZR is engineered for strength, stability, and reliability. Designed with simplicity in mind, the ZR offers everything you need for a high-performing gym setup, all at a more affordable price point.

SPECIFICATIONS

Length: 73.11"

Width: 58.5"

Height: 95.9"

Steel Notes: 3"x 3" 11 gauge steel

Frame Color: Matte Black Powder Coat Finish

Product Weight:

-Empty Frame: 275.26 lbs

-With J-Cup & Spotter Arm: 354.15 lbs

-With J-Cup Only: 308.64 lbs

Standard Configuration

J Hooks x 2 pcs , Spotter arms x 2 pcs, Weight plate storage Set x 1 , Bar storage x 2 pcs, Pull up bar Set x 1

HR1



Our HR1 Half Rack is the perfect choice for high-volume gyms that require strength, stability, and long-term reliability. Our HR1 features the same strength and durability of our entire line with an appealing customizable logo arch and all the extras that will separate your gym from the rest. Extra storage capabilities, numerous expansion accessories and stainless-steel trim make the HR1 the natural choice for your operation.

The HR1 also comes in an 8-foot version, the HR3, offering a more compact option while retaining the same strength and adaptability.

SPECIFICATIONS

Length: 73.5"

Width: 61.6"

Height: 105"

Steel Notes: 3"x 3" 11-gauge steel

Frame Color: Matte Black Powder Coat Finish

Product Weight: 540 lbs

Standard Configuration

J Hooks x 2 pcs , Spotter arms x 2 pcs, Weight plate storage Set x 1 , Bar storage x 4 pcs, Landmine Set x 1, Band pegs Set x 1, Pull up bar Set x 1.

HR2



The HR2 builds on the same foundation as the HR1, adding upgrades such as stainless-steel upright covers engineered for high-volume training facilities, enhancing durability while allowing easier maintenance and replacement. Aesthetically, its integrated arch is fully customizable for your logo or facility signage.

The HR2 also offers an 8-foot version, the HR4, providing a more compact option while maintaining the same durability and versatility.

SPECIFICATIONS

Length: 73.5"

Width: 61.6"

Height: 105"

Steel Notes: 3"x 3" 11-gauge steel

Frame Color: Matte Black Powder Coat Finish

Product Weight: 584 lbs

Standard Configuration

J Hooks x 2 pcs , Spotter arms x 2 pcs, Weight plate storage Set x 1 , Bar storage x 4 pcs, Landmine Set x 1, Band pegs Set x 1, Protective wear cover Set x 1, Pull up bar Set x 1.

FULL RACKS

PR1



Our PR1-POWER RACK features a sturdy and durable framework, which ensures stability and reliability for thousands of workouts. With its full array of expandable options and available accessories, the PR-1 opens a whole world of different work-out possibilities. Built-in storage and extra safety features make the PR1 the go to option, for giving your customers what they need for a full workout.

SPECIFICATIONS

Length: 79.4"
Width: 73.5"
Height: 105"
Steel Notes: 3" x 3" 11-gauge steel
Frame Color: Matte Black Powder Coat Finish
Product Weight: 740 lbs

Standard Configuration

J Hooks x 2 pcs , Spotter arms x 2 pcs, Weight plate storage Set x 1 , Bar storage x 4 pcs, Landmine Set x 1, Band pegs Set x 1, Pull up bar Set x 2.

DR1



Dual-Sided Versatility: The DR1 - Double-Sided Half Rack is an uncompromising upgrade, combining two HFR1's into a dual-sided powerhouse. Twice the storage capacity. Twice the number of available user workouts in a smaller footprint than two separate racks. All with the same sturdy construction, attention to detail and thoughtful efficiency as our other racks.

SPECIFICATIONS

Length: 123.3"
Width: 73.5"
Height: 105"
Steel Notes: 3" x 3" 11-gauge steel
Frame Color: Matte Black Powder Coat Finish
Product Weight: 1080 lbs

Standard Configuration

J Hooks x 4 pcs , Spotter arms x 4 pcs, Weight plate storage Set x 2 , Bar storage x 8 pcs, Landmine Set x 2, Band pegs Set x 2, Pull up bar Set x 2.

WALL MOUNTED RACKS

A30



Introducing our A30, this wall-mounted rack is as sturdy as any of our racks but delivers performance in a compact area. When space is at a premium, our A30 optimizes square footage but won't sacrifice safety or versatility. With multiple adjustment points to accommodate different heights and body types, the A30 ensures a comfortable and stable workout experience.

SPECIFICATIONS

Weight: 196 lbs
Length: 17"
Width: 50"
Height: 88.5" or 96"
Steel Notes: 3" x 3" 11-gauge steel
Frame Color: Matte Black Powder Coat Finish

Standard Configuration

J Hooks x 2 pcs , Spotter arms x 2 pcs, Pull up bar Set x 1.

C60



The C60 wall-mounted offers all the space saving feature as the A30 but with a bit more added room with its extended wall mounts. When space is still an issue but not as critical, the C60 is your choice. It has all the same multiple adjustment points to accommodate all your customers with the same standards of strength and durability.

SPECIFICATIONS

Weight: 220 lbs
Length: 32.8"
Width: 50"
Height: 88.5" or 96"
Steel Notes: 3" x 3" 11-gauge steel
Frame Color: Matte Black Powder Coat Finish

Standard Configuration

J Hooks x 2 pcs , Spotter arms x 2 pcs, Pull up bar Set x 1.

POWER STREAM

FORCE RACK ZR

Strength Without Sacrifice

Built for absolute stability and engineered for relentless training, the Force Rack empowers athletes to push harder, recover faster, and dominate every rep—without sacrificing an inch of your training floor.

If you're a coach, lifter, or facility that demands top-tier performance without dead weight, the Force Rack isn't just the smarter choice—it's the only choice.

Essential Strength. Zero Waste. Maximum Impact.

Stop overpaying for steel you don't need. Stop wasting valuable floor space.

The Force Rack delivers the same premium 3" x 3", 11-gauge steel trusted by elite programs—condensed into a tighter, meaner footprint that crushes performance, not space.



SPECIFICATIONS

Length: 73.11"

Width: 58.5"

Height: 95.9"

Steel Notes: 3" x 3" 11 gauge steel

Frame Color: Matte Black Powder Coat Finish

Product Weight:

-Empty Frame: 275.26 lbs

-With J-Cup & Spotter Arm: 354.15 lbs

-With J-Cup Only: 308.64 lbs

Standard Configuration

J Hooks x 2 pcs , Spotter arms x 2 pcs, Weight plate storage Set x 1 , Bar storage x 2 pcs, Pull up bar Set x 1

FORCE RACK ZR

Built Like the Best, Designed for More

SPECIFICATIONS

- Streamlined frame for easy installation, relocation, and maximum space efficiency.

- Premium 3" x 3", 11-gauge steel for uncompromising durability in high-traffic training environments.

- Integrated plate storage and reinforced welds to keep your space organized, clean, and competition-ready.

- Elite stability—no wobble, no compromise.

- Backed by a commercial warranty for long-term, worry-free performance.



Length: 73.11"

Width: 58.5"

Height: 95.9"

Steel Notes: 3" x 3" 11 gauge steel

Frame Color: Matte Black Powder Coat Finish

Product Weight:

-Empty Frame: 275.26 lbs

-With J-Cup & Spotter Arm: 354.15 lbs

-With J-Cup Only: 308.64 lbs

Commercial Warranty: 10 year frame & welds/1 year parts/90 days misc.

Standard Configuration

J Hooks x 2 pcs, Spotter arms x 2 pcs, Weight plate storage Set x 1, Bar storage x 2 pcs, Pull up bar Set x 1

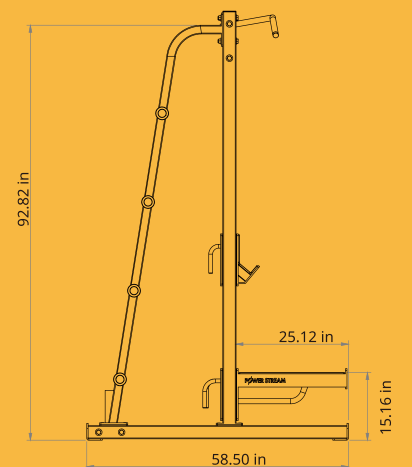
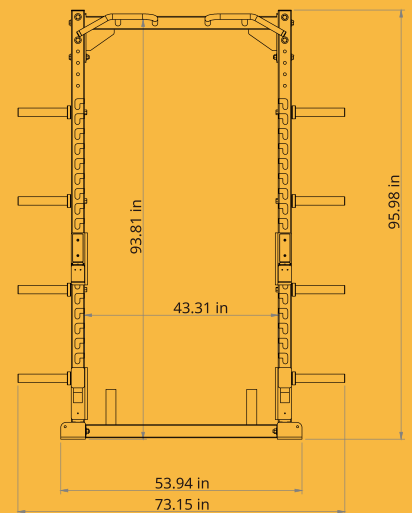

Why Choose ZR ?

If you're looking for dependable strength, no-nonsense functionality, and long-term durability—all without overspending—the ZR Half Rack is your ultimate workhorse. Train harder, train smarter, and trust your rack to keep up.

SSO RACKS

Storage Racks



Our SSO Storage Systems deliver a space-efficient, integrated solution for organizing dumbbells, kettlebells, and other strength accessories. Designed to mount seamlessly to the rear of HR and PR rack systems, SSO maximizes vertical space while keeping training areas clean, accessible, and performance-ready.

Available configurations include:

- Kettlebell Divider Shelf × 1
- Dumbbell Divider Shelf (5–35 lb) × 1
- Dumbbell Divider Shelf (40–75 lb) × 1
- Kettlebell Hanging Board × 3
- Dumbbell Hanging Board × 5

SPECIFICATIONS

Height: 85.6" or 93.3"
Steel Notes: 3" x 3" 11-gauge steel
Frame Color: Matte Black Powder Coat Finish
Product Weight: 414 lbs
Patent No.: 18/826,872

BENCHES

Multi-Adjustable Bench



Our Multi-Adjustable Bench is more than just a standard bench. It provides quick and easy adjustments at any angle to meet your workout requirements while also allowing for easy movement throughout your gym.

MATERIAL

Finish: Powder-Coated Black
Upholstery Material: Hefty Grip Vinyl
Frame Material: 2" x 3" – 11 Gauge Steel
 6 positions – 0° / 30° / 45° / 60° / 75° / 85°

SPECIFICATIONS

Bench Height: 17 inches
Overall Length: 56.5"
Overall Width: 24.75"
Back Pad Length: 40"
Back Pad Width: 12"
Seat Pad Length: 12"
Seat Pad Width: 12"
Seat Pad Thickness: 2.5"
Weight: 121.25 lbs

Pop 'n' Lock Bench



Pop 'n' Lock Bench — Precision. Power. Comfort. Engineered for serious strength training, the Pop 'n' Lock Bench delivers unmatched performance and rock-solid stability. Its precision sliding rail system lets you adjust positions in seconds—keeping workouts fast, fluid, and efficient.

Ergonomically contoured pads ensure maximum comfort and perfect body alignment:

Tapered backrest — narrow at the top for shoulder mobility, wider at the bottom for full support.

Shaped seat pad — narrow at the front for movement freedom, wider at the back for stability.

Built for high-traffic, professional gyms, the Pop 'n' Lock Bench combines durability, efficiency, and user-focused comfort—so every rep feels stronger, smoother, and more controlled.

SPECIFICATIONS

Bench Height: 17 inches
Overall Length: 56.5"
Overall Width: 24.75"
Weight: 101.4 lbs

5 positions – 0° / 30° / 45° / 75° / 90°

Patent No. : Patent Pending